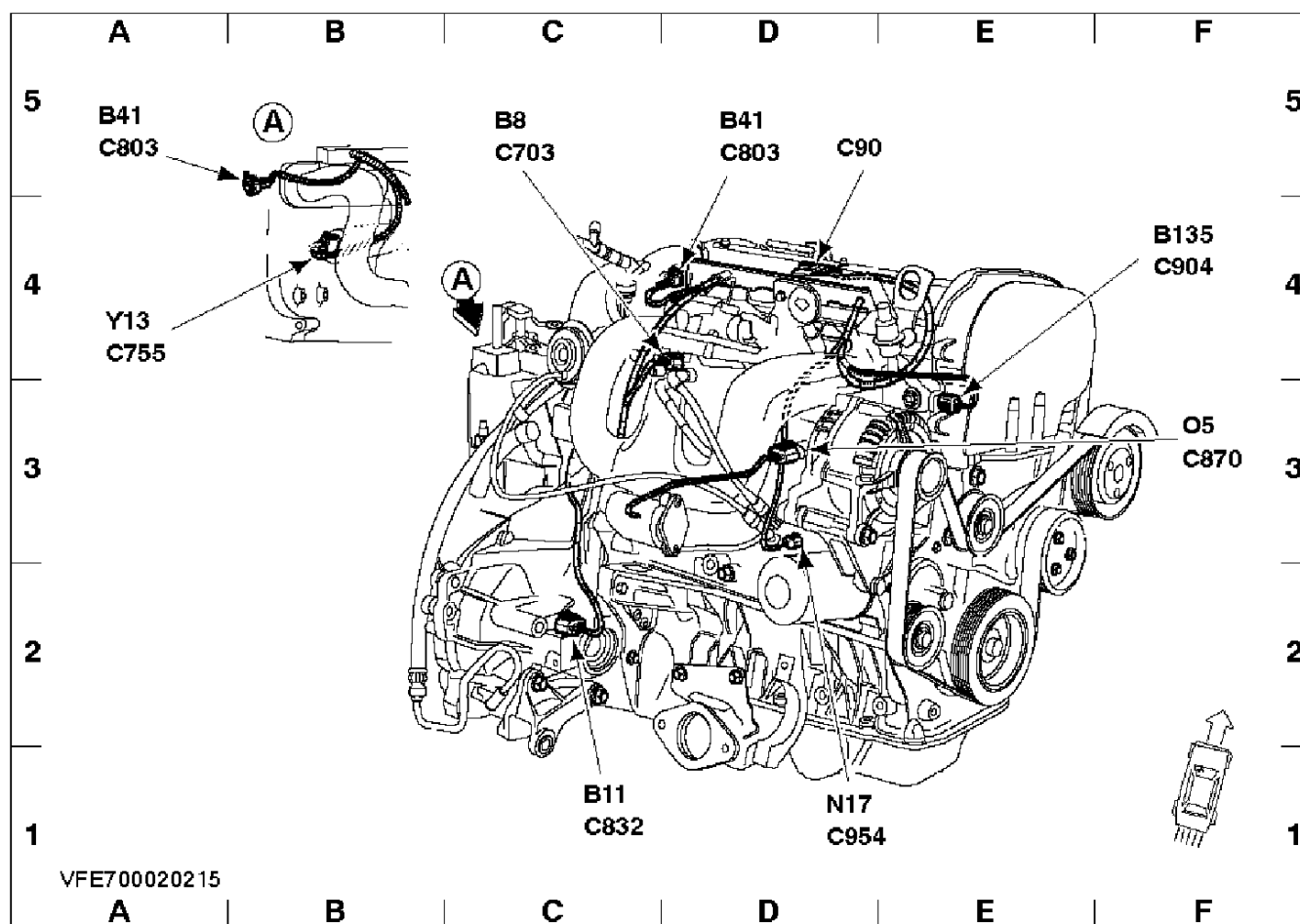

C904

➡ Vista del conector

C904, ZETEC-E, caja de cambio manual

➡ Vista del conector

culata, ZETEC-E (F 4)



C904, Motores diesel, sin aire acondicionado

➡ Vista del conector

culata, Duratorq TDCi (F 4)

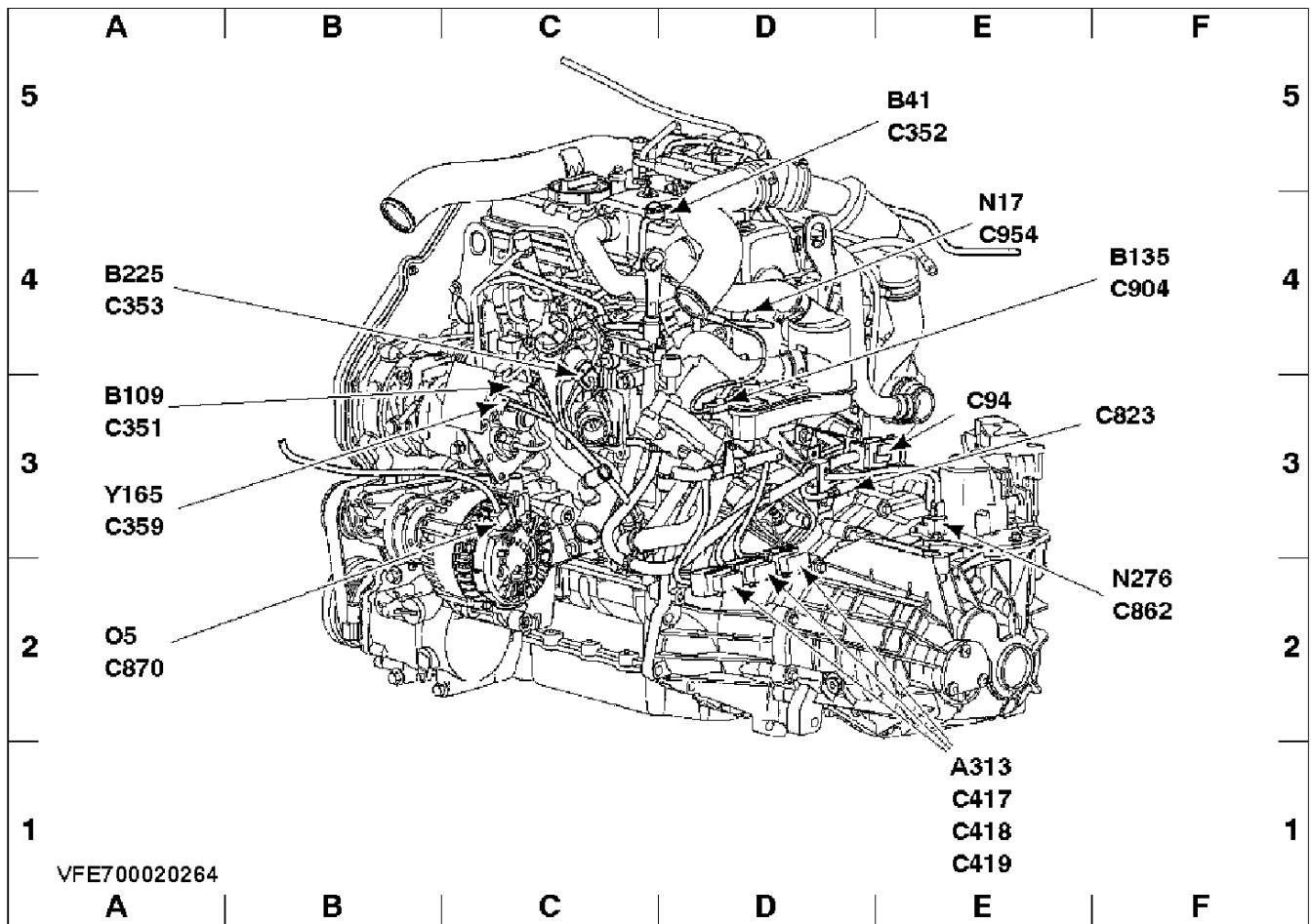

culata, Endura-DI (C 1)

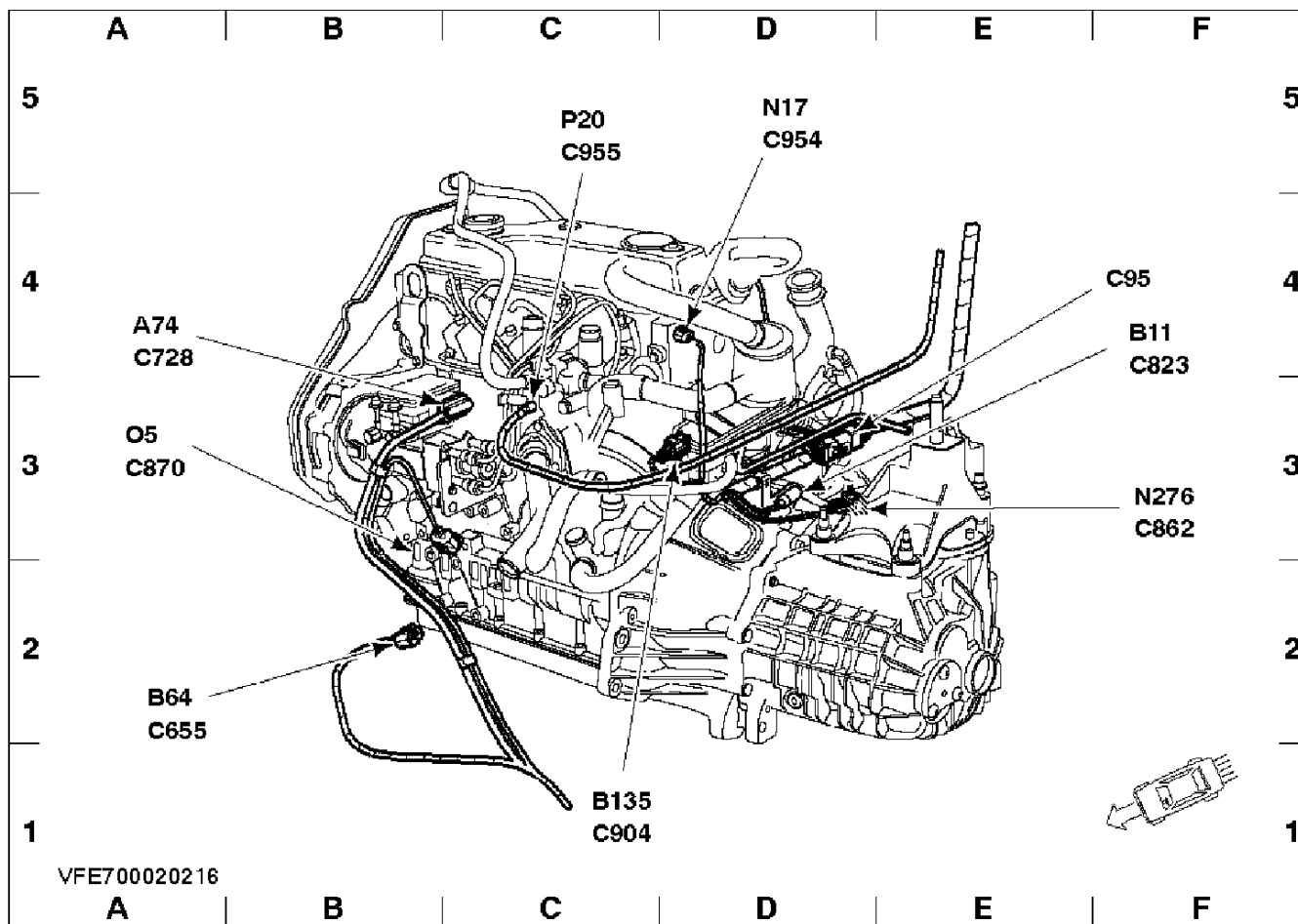

C904, Motores diesel, con aire acondicionado

➤ Vista del conector

culata, Duratorq TDCi (F 4)

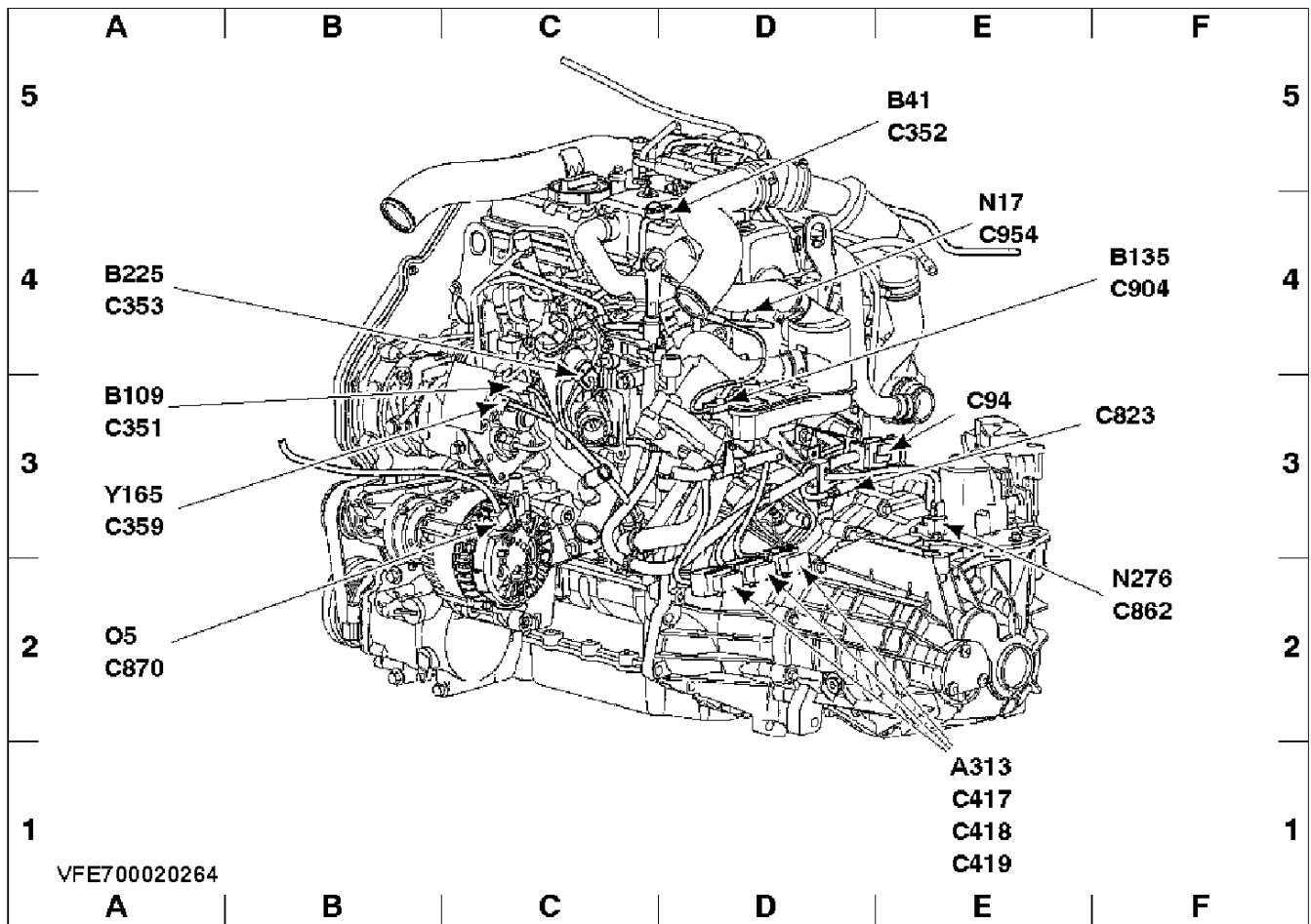

culata, Endura-DI (C 1)

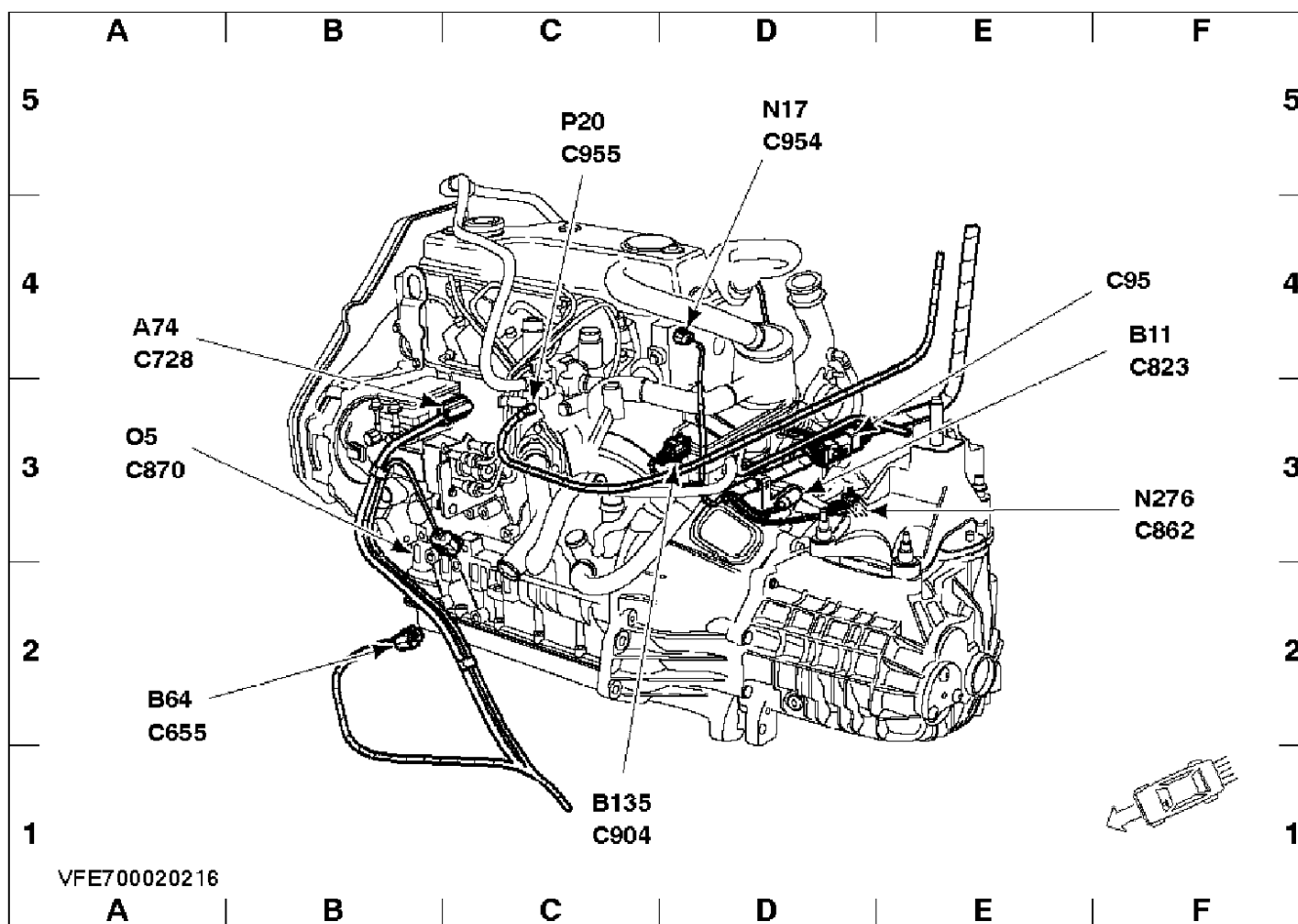

C904, Duratec-RS, sin aire acondicionado

➡ Vista del conector

culata, Duratec-RS

C904, Duratec-RS, con aire acondicionado

➡ Vista del conector

culata, Duratec-RS

C904, Aire acondicionado, ZETEC-E, antes de 08/2000, caja de cambio manual

➡ Vista del conector

culata, ZETEC-E (F 4)

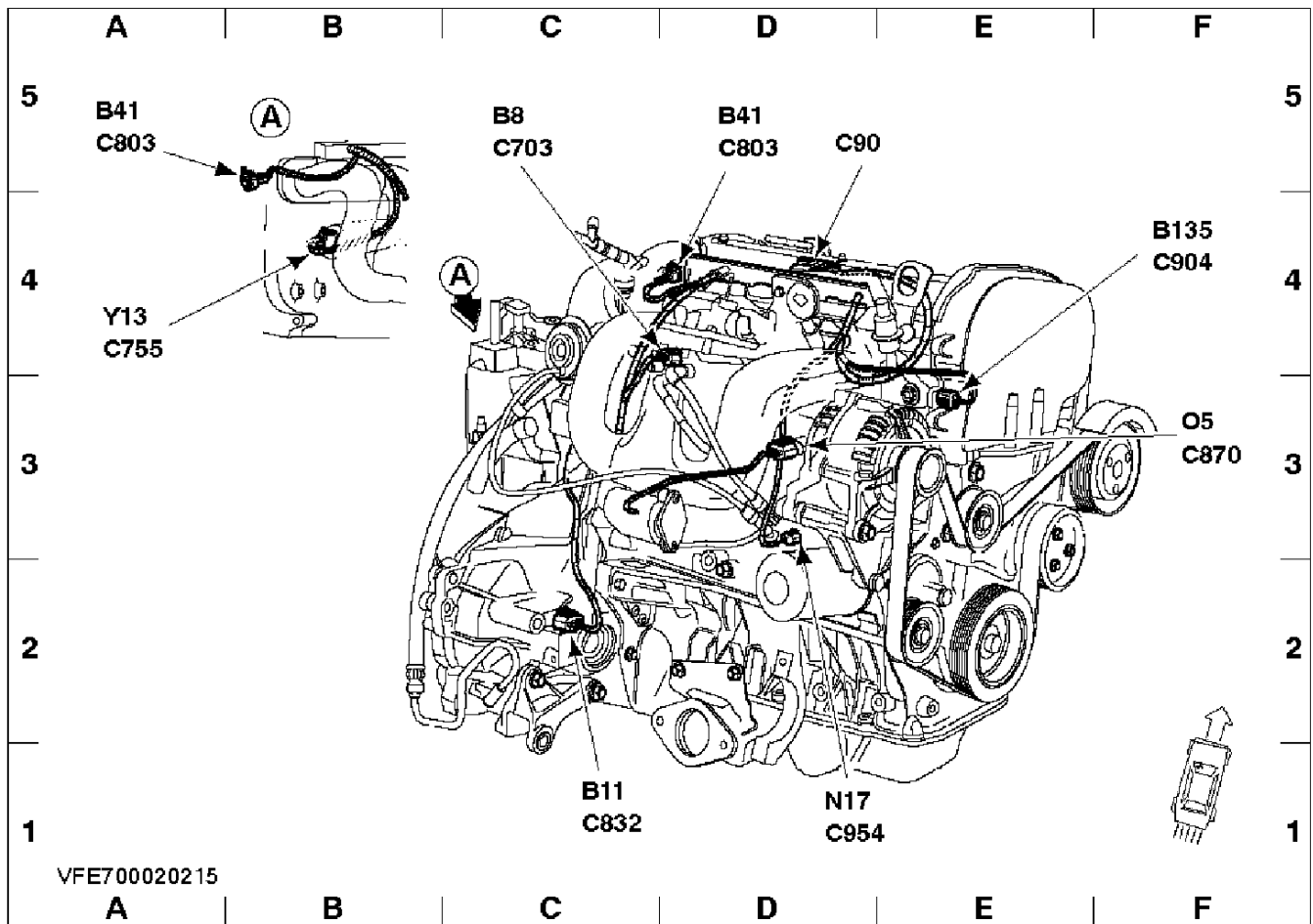

C904, Aire acondicionado, ZETEC-E, a partir de 08/2000, caja de cambio manual

➡ Vista del conector

culata, ZETEC-E (F 4)

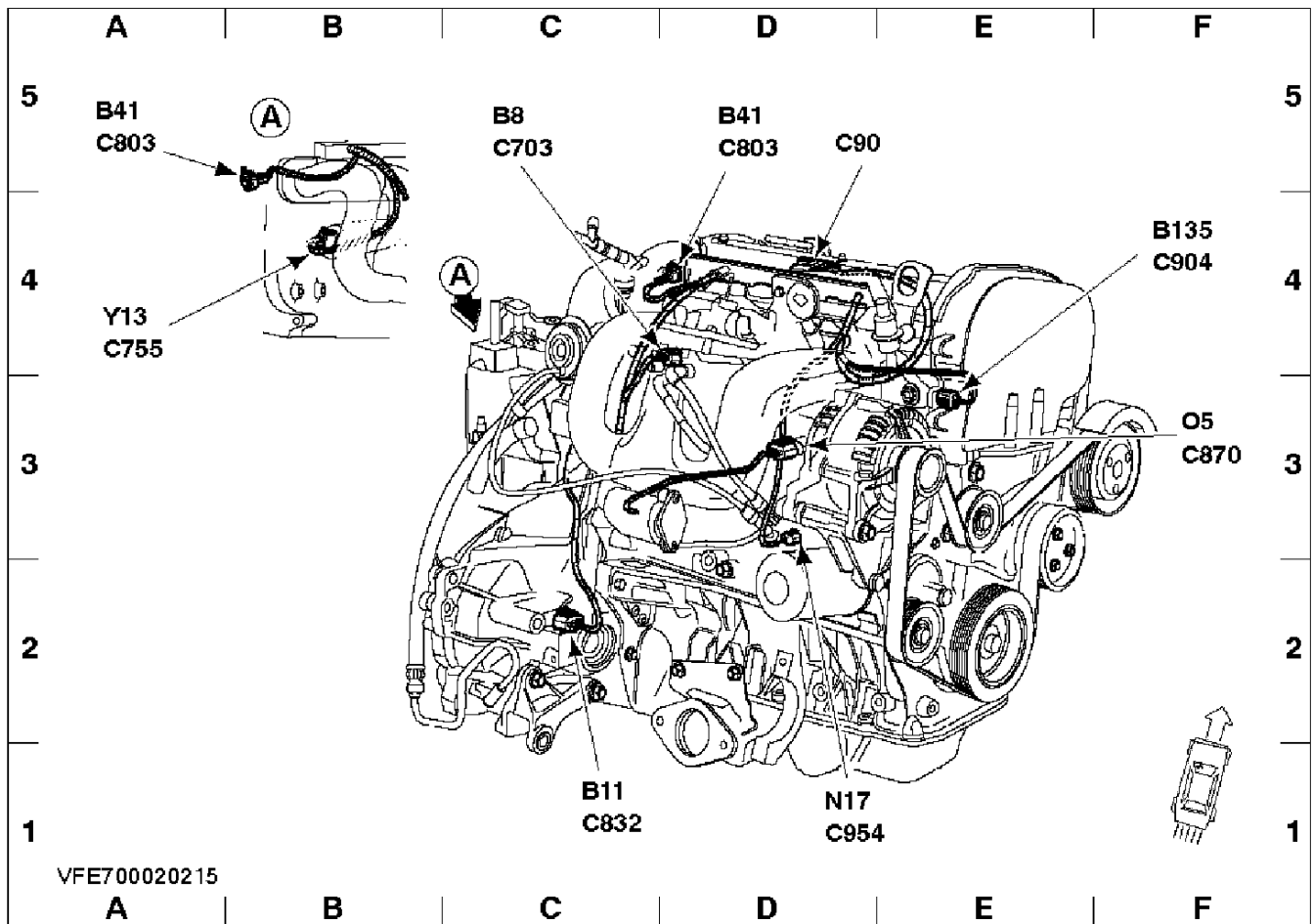

C904, Aire acondicionado, Motores diesel

➤ Vista del conector

culata, Duratorq TDCi (F 4)

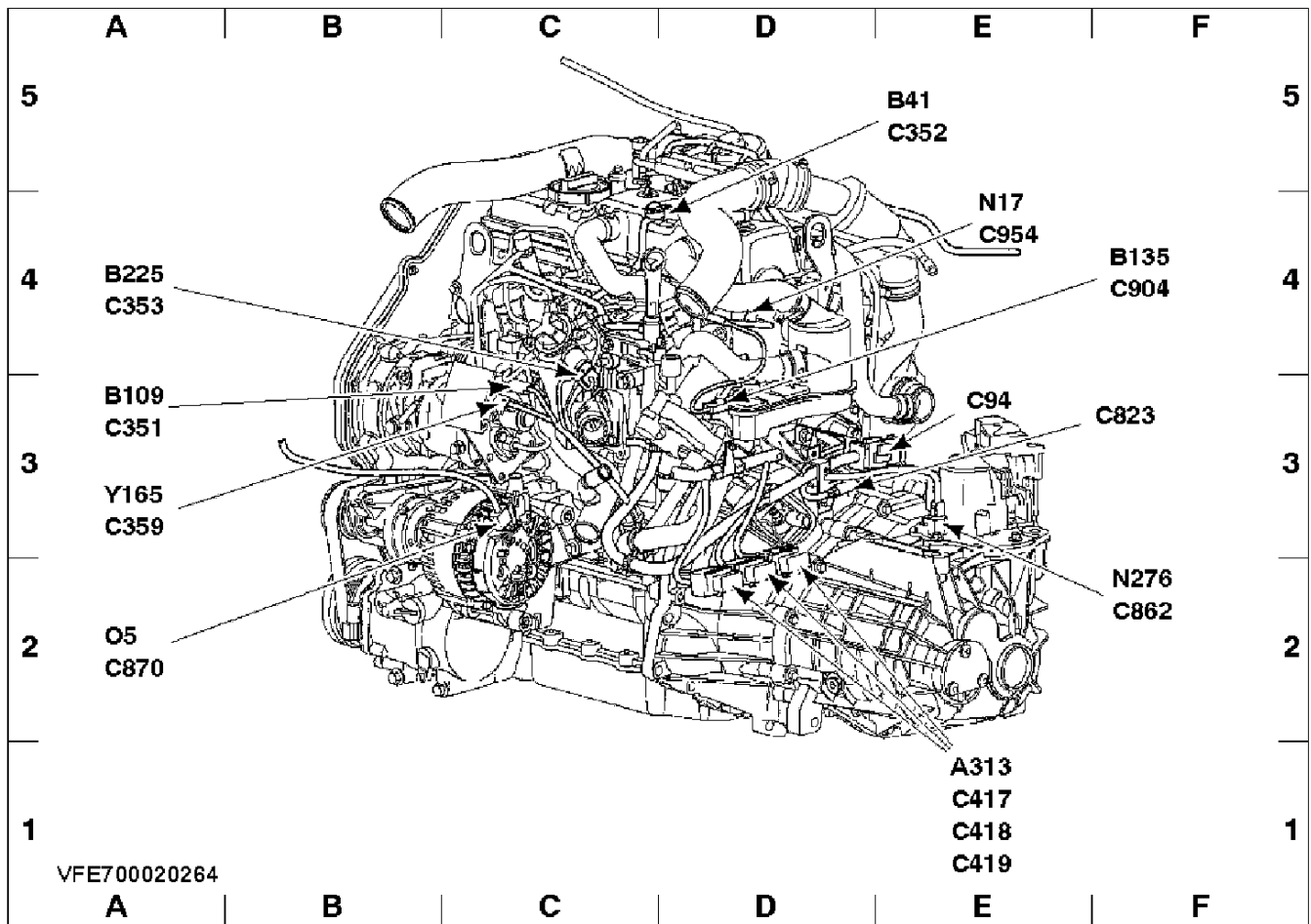

culata, Endura-DI (C 1)

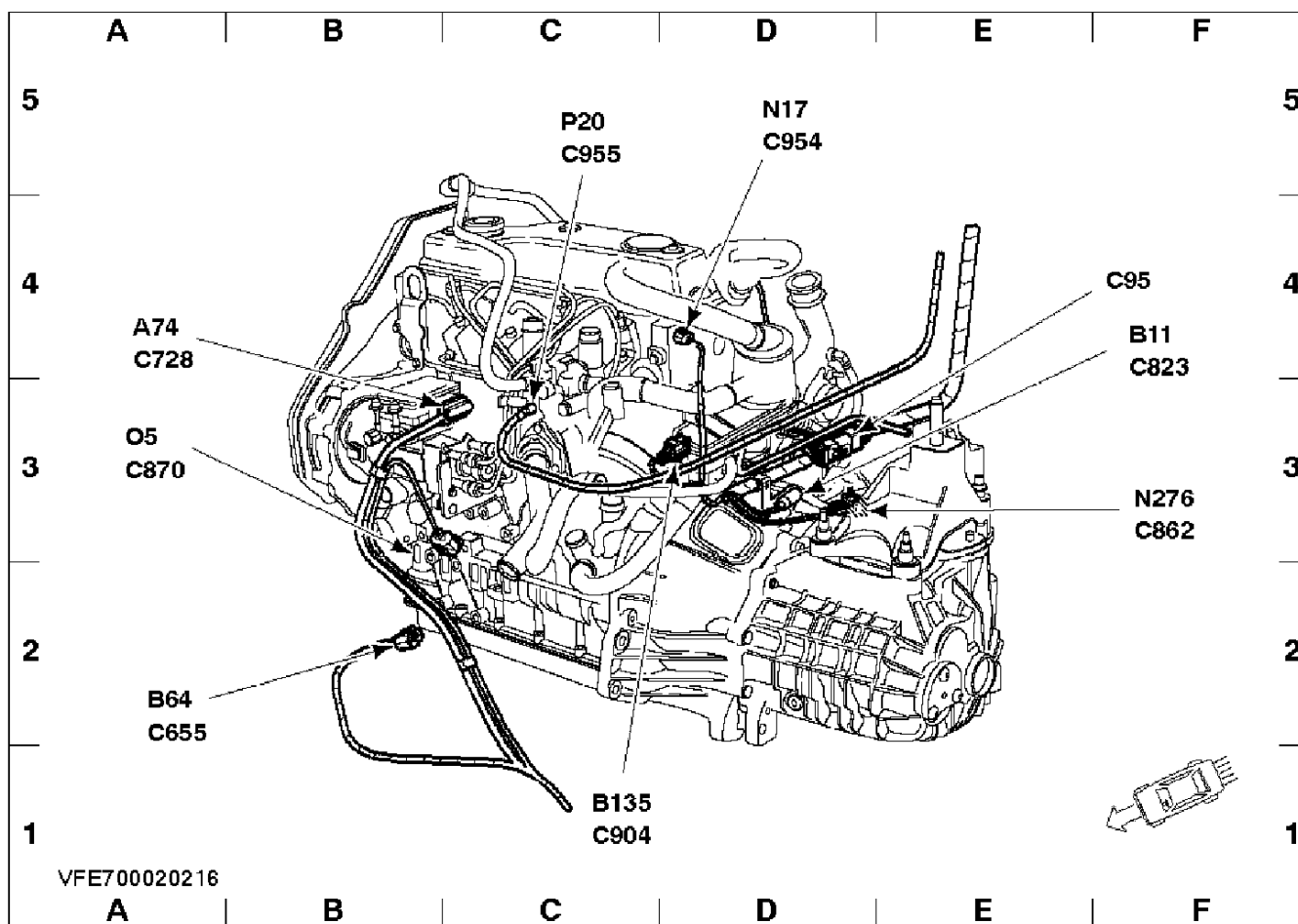

C904, Endura-DI

➤ Vista del conector

culata, Endura-DI (C 1)

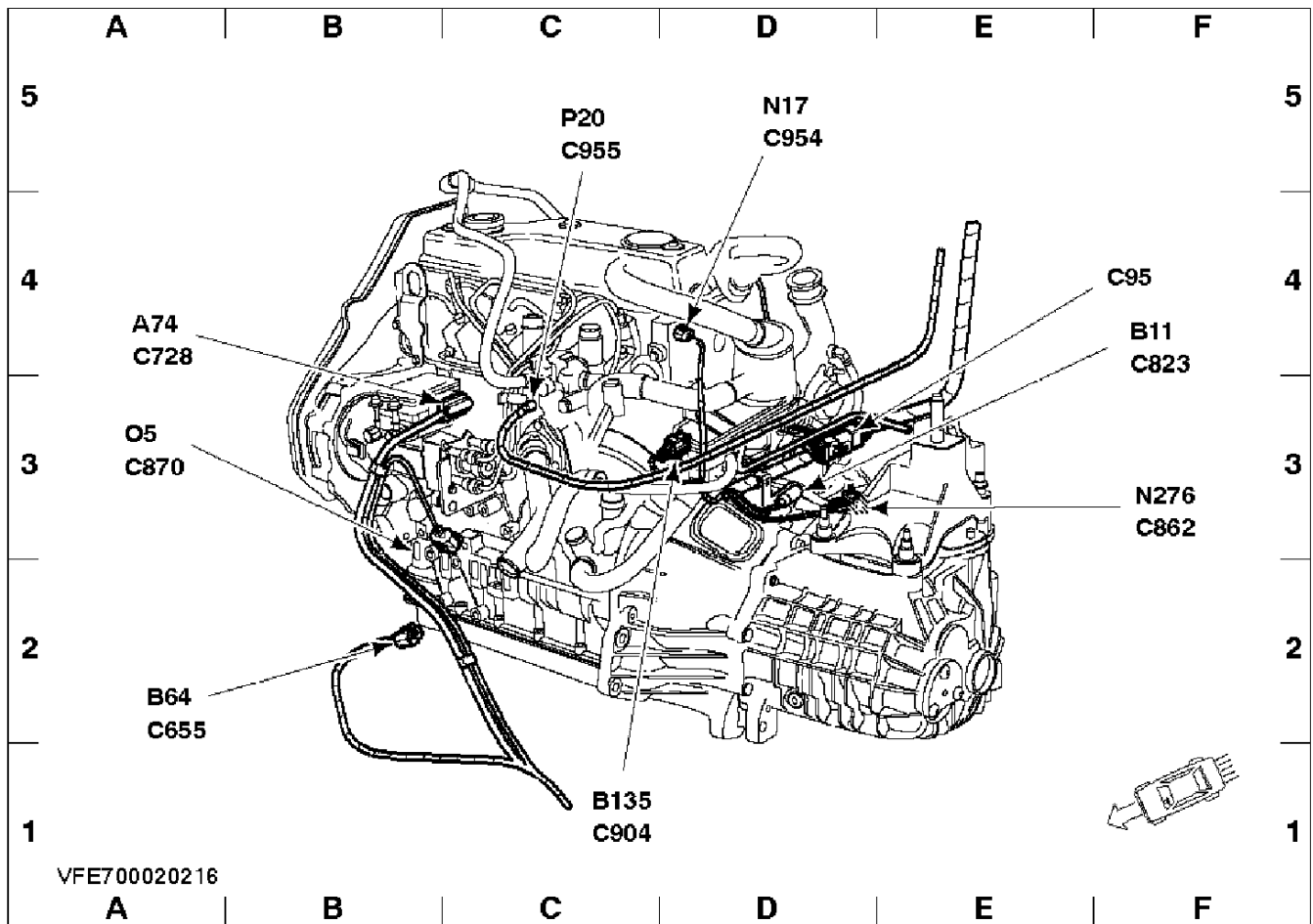

C904, Duratorq TDCi

➤ Vista del conector

culata, Duratorq TDCi (F 4)

